

MEMORANDUM

TO: MAYOR AND CITY COMMISSION

FROM: CITY ATTORNEY'S OFFICE

DATE: January 7, 2019

**RE: Agreement for Supplemental Skilled Labor –
Welding – for McIntosh and Larsen Power
Plants**

Attached hereto for your consideration is approval of an Agreement for Supplemental Skilled Labor – Welding - for the McIntosh and Larsen Power Plants and Winston Generating Facility. Each year, Lakeland Electric requires additional skilled labor in various disciplines to supplement its existing workforce during times of increased workload such as planned outages.

Accordingly, on October 31, 2018, the City's Purchasing Department issued Invitation to Bid (ITB) No. 8332B seeking qualified industrial maintenance contractors to supply highly skilled and certified journeyman industrial welders on an as-needed basis to perform journeyman level, advanced welding procedures for the maintenance of high pressure steam power plant equipment in Lakeland Electric's power generating facilities. A total of eight (8) firms responded to the City's ITB.

Upon evaluation, staff determined that the following four (4) listed firms are capable of providing the most qualified, cost effective supplemental labor during the term of the Agreement:

- Preferred Maintenance and Construction, Inc. – Mulberry, FL
- Titan Contracting – Homosassa, FL
- WEC Carolina Energy Solutions, LLC – Rock Hill, SC
- MOR PPM, Inc. – Port St. Lucie, FL

The Agreement with each firm will become effective upon approval by the City Commission and continue through September 30, 2021. The Agreement contains two (2) additional one (1) year renewal options upon mutual written agreement of the parties. All services provided will be performed in accordance with the terms and conditions contained in the City's Bid Specifications and the firms' bid responses. The total estimated cost of the first year's supplemental labor – Welding - is \$250,000 and is included in Lakeland Electric's FY19 budget. The estimated cost for the three (3) year Agreement is \$750,000.

It is recommended that the appropriate City officials be authorized to approve this Agreement for Supplemental Skilled Labor – Welding - at the McIntosh and Larsen Power Plants and Winston Generating Facility with the above-specified firms.

attachment



RISK MANAGEMENT & PURCHASING
1140 EAST PARKER STREET
LAKELAND, FL 33801

NOTICE TO BIDDERS

INVITATION TO BID

SUPPLEMENTAL SKILLED LABOR - WELDING

At The

MCINTOSH and LARSEN POWER PLANTS

AND WINSTON GENERATING STATION

OCTOBER 31, 2018

BID NO. 8332B

Sealed bids will be received by the Purchasing Manager, City of Lakeland, Florida, 1140 East Parker Street, Lakeland, Florida 33801 **until 2:30 p.m. – Wednesday – November 28, 2018.** Bids received after this specified time and date will not be considered. The sealed bids will be publicly opened and read aloud on the same date and time in the office of the Purchasing Manager for the following:

Bid Documents may be requested by visiting our Website at <http://www.lakelandgov.net/purchasing> or by contacting the City of Lakeland Purchasing Division @ (863) 834-6780. Bid Documents are Required for Bid Submittal. Any Bidder that Does Not Have a City of Lakeland Oracle iSupplier Number Should Visit the Above Website and Register as an Oracle Supplier.

THE CITY OF LAKELAND IS SEEKING BIDS FROM QUALIFIED INDUSTRIAL MAINTENANCE CONTRACTORS TO SUPPLY HIGHLY SKILLED AND CERTIFIED INDUSTRIAL WELDERS (HEREAFTER REFERRED TO AS “WELDER”, “TUBE WELDER” OR “PLATE WELDER”) ON AN AS-NEEDED BASIS IN STRICT ACCORDANCE WITH THE TERMS AND CONDITIONS SET FORTH IN THIS SPECIFICATION. CONTRACT WELDER SHALL BE UTILIZED TO ASSIST OWNER IN SUPPLEMENTING ITS EXISTING WORKFORCE DURING PLANNED OUTAGES, AND OTHERWISE AS OWNER SEES FIT, AND WILL BE REQUIRED TO PERFORM JOURNEY LEVEL, HIGHLY SKILLED JOURNEY LEVEL WORK, PERFORMING ADVANCED WELDING PROCEDURES. WORK INVOLVES THE PERFORMANCE OF A VARIETY OF TASKS IN HIGH PRESSURE CODE WELDS, ALLOY WELDS, CARBON STEEL WELDS, AND SIMILAR WELDS OF AN ADVANCED NATURE, AND REQUIRING A HIGH DEGREE OF TECHNICAL KNOWLEDGE, SKILL AND PRECISION. DUTIES INCLUDE THE MECHANICAL MAINTENANCE OF HIGH PRESSURE STEAM POWER PLANT EQUIPMENT, AND THE LIMITED SUPERVISION ON SUBORDINATES. WORKERS ARE ASSIGNED TO SPECIFIC JOBS BY ORAL AND/OR WRITTEN INSTRUCTIONS, WHICH MAY INCLUDE SKETCHES AND BLUEPRINTS. THIS WORK IS USUALLY PERFORMED IN TWO-MAN TEAMS, WITH GUIDANCE OR ASSISTANCE GIVEN BY OWNER’S WELDING FOREMAN OR JOURNEYMEN ON DIFFICULT AND COMPLEX JOBS.

THE BIDS SUBMITTED AND THE PURCHASE ORDER, IF AWARDED, SHALL BE IN COMPLETE ACCORDANCE WITH, WITHOUT LIMITATION, THIS INVITATION TO BID, SPECIFICATION, ALL CODES, REQUIREMENTS AND REGULATIONS REFERENCED THEREIN.

Note: This Annual Supply Requirement, if placed, shall be Firm and Valid, Beginning with the Issuance of a Purchase Order through September 30, 2021, with an Option for Two (2), One (1) Year Renewals upon Mutual Written Consent.

Note: Mandatory Pre-Bid Meeting & Site Visit: The City of Lakeland has scheduled a **Mandatory Pre-Bid Meeting & Site Visit on Wednesday, November 14, 2018 at 10:00 a.m.** in the Administration Building Conference Room at the McIntosh Power Plant, located at 3030 East Lake Parker Drive, Lakeland, Florida. **Note: Only those qualified contractors in attendance shall be eligible to bid.**

Questions regarding this invitation to bid should be **in writing** and should reference the above Bid number. Submit all questions to **Ms. Linda Alspaugh, Purchasing Agent**, via e-mail at **purch@lakelandgov.net** or fax **(863) 834-6777**.

CLARIFICATION AND/OR EXCEPTIONS OF DOCUMENTATION

Bidders requiring clarification or having a dispute with these documents must advise the City Purchasing Division of the nature of the required clarification or basis of the dispute, in writing, no later than **November 21, 2018**. If no written contact has been made by this specified date, the Bidder waives the right to any future consideration and accepts the documents as published and/or revised by the City. **Additionally, submitting a signed bid shall be construed as a total compliance statement.** **Note:** Any use of brand names (manufacturer) in this invitation and specification is for Bidder convenience only and shall not limit this offering. Equal or better equipment and alternate bids may be given consideration.

FLORIDA PUBLIC RECORDS LAW

Qualification submittal information shall be subject to Chapter 119, Florida Statutes, generally known as the "Florida Public Records Law." This statute provides that all documents, papers, records and similar material produced or received by an agency or political subdivision of the State are subject to public inspection and review under reasonable conditions and at reasonable times. Accordingly, unless specifically exempted by law, all bids and materials received with bids, marketing information, quotations, proposals, specifications, correspondence, forms, contracts, bonds, financial statements, prospectus, corporate resumes, product summaries, lab reports, inspection and test reports and any other such material will be considered a matter of public record. The City and its staff cannot regard any document, information or data as proprietary or confidential unless so advised by the City Attorney.

Additionally, should a Contractor enter into an Agreement with the City, the Contractor shall comply with Florida Statute Chapter 119, the Florida Public Records Act as it relates to records kept and maintained by Contractor in performance of services pursuant to this Agreement. In accordance with Florida Statute §119.0701, the Contractor shall keep and maintain public records required by the City in performance of services pursuant to the contract. Upon request from the City's custodian of public records, Contractor shall provide the City with a copy of the requested records or allow the records to be inspected or copied within a reasonable time at a cost that does not exceed the cost provided pursuant to Florida Statute Chapter 119 or as otherwise provided by law. Contractor shall ensure that public records that are exempt or confidential and exempt from public records disclosure requirements are not disclosed except as authorized by law for the duration of the contract term and following completion of the contract if the Contractor does not transfer the records to the City. Contractor shall, upon completion of the contract, transfer, at no cost, to the City all public records in possession of the Contractor or keep and maintain public records required by the City to perform services pursuant to the contract. If the Contractor transfers all public records to the City upon completion of the contract, the Contractor shall destroy any duplicate public records that are exempt or confidential and exempt from public records disclosure requirements. If the Contractor keeps and maintains public records upon completion of the contract, the Contractor shall meet all applicable requirements for retaining public records. All records stored electronically must be provided to the City, upon request from the City's custodian of public records, in a format that is compatible with the information technology systems of the City.

IF THE CONTRACTOR HAS QUESTIONS REGARDING THE APPLICATION OF CHAPTER 119, FLORIDA STATUTES, TO THE CONTRACTOR'S DUTY TO PROVIDE PUBLIC RECORDS RELATING TO THIS CONTRACT, CONTACT THE CUSTODIAN OF PUBLIC RECORDS: KEVIN COOK - DIRECTOR OF COMMUNICATIONS AT: PHONE: 863-834-6264, E-MAIL: KEVIN.COOK@LAKELANDGOV.NET, ADDRESS: ATTN: COMMUNICATIONS DEPARTMENT, 228 S. MASSACHUSETTS AVE., LAKELAND, FLORIDA 33801.

EXPARTE COMMUNICATION

Please note that to insure the proper and fair evaluation of a bid, the City of Lakeland prohibits exparte communication (i.e., unsolicited) initiated by the Bidder to the City Official or Employee evaluating or considering the bids prior to the time a bid decision has been made. Communication between Bidder and the City will be initiated by the appropriate City Official or Employee in order to obtain information or clarification needed to develop a proper and accurate evaluation of the bids. Exparte communication may be grounds for disqualifying the offending Bidder from consideration or award of the bid then in evaluation or any future bid.

INSURANCE AND SAFETY REQUIREMENTS

All insurance shall be secured from or countersigned by an agent or surety company recognized in good standing and authorized to do business in the State of Florida.

The Contractor shall, within ten (10) days of notification of award and **prior to commencement of work, take out and maintain in full force and effect minimum insurance coverage as specified in the attached requirements.** This insurance shall remain in force and effect throughout the duration of the contract.

A **certificate of existing insurance** coverage should be submitted with the bid as proof of insurability. If the current coverage does not meet the bid requirements, then the Bidder should request an affidavit of insurability from the Bidder's insurance agent that certifies that the requirements can and will be met. Failure to provide adequate insurance coverage may be cause for disqualification as non-responsive to the bid requirements. The Contractor agrees to accept and abide by the City of Lakeland safety regulations in complete accordance with the attached requirements.

INDEMNIFICATION AGREEMENT

The Contractor agrees to indemnify and hold harmless the City of Lakeland in complete accordance with the attached requirements. This agreement shall be signed, notarized and returned with the bid submittal. Failure to provide the Hold Harmless Indemnification Agreement may be cause for disqualification as non-responsive to the bid requirements.

PUBLIC ENTITY CRIMES

A person or affiliate who has been placed on the convicted vendor list following a conviction for a public entity crime may not submit a bid on a contract to provide any goods or services to a public entity, may not submit a bid on a contract with a public entity for the construction or repair of a public building or public work, may not submit bids on leases of real property to a public entity, may not be awarded or perform work as a contractor, supplier, subcontractor, or consultant under a contract with any public entity, and may not transact business with any public entity in excess of the threshold amount provided in Section 287.017, for **CATEGORY TWO** for a period of 36 months from the date of being placed on the convicted vendor list.

DRUG-FREE WORKPLACE CERTIFICATION

By submitting a bid in response to this Invitation to Bid, you are certifying that your company is a drug-free workplace in accordance with Florida Statute 287.087.

SUSPENSION AND DEBARMENT CERTIFICATION

By submitting a bid in response to this Invitation to Bid, you are certifying that your company, pursuant to 49 CFR Part 29: (1) is not presently suspended or debarred as, and/or listed on the U.S. General Services Administration's System for Award Management (SAM) as such; and (2) will at all times remain eligible to bid for and perform the services subject to the requirements set forth herein and other applicable laws. Bidder agrees that any contract awarded to Bidder will be subject to termination by the City if Contractor or its subcontractors fail to comply or maintain such compliance.

CONFLICT OF INTEREST / STATEMENT OF NON-COLLUSION

The award hereunder is subject to Chapter 112, Florida Statutes. All respondents must disclose with their bid the name of any officer, director, or agent who is also an employee of the City of Lakeland. Further, all respondents must disclose the name of any City of Lakeland employee who owns, directly or indirectly, an interest of five percent (5%) or more of the respondent's firm or any of its branches.

The respondent shall certify that he/she has not, either directly or indirectly, entered into any agreement, participated in any collusion, or otherwise taken any action in restraint of free competitive bidding in connection with the bid and that the respondent is not financially interested in, or otherwise affiliated in a business way with any other respondent on the same land or improvements.

ADDENDA

It is the Bidder's responsibility to contact the Purchasing Division prior to submitting a bid to ascertain if any addenda have been issued, to obtain all such addenda and return executed addenda with the bid.

The failure of a Bidder to submit acknowledgement of any addenda that affects the bid price(s) may be considered an irregularity and may be cause for rejection of the bid.

TERMS AND CONDITIONS OF AGREEMENT

A copy of the agreement to be entered into with the successful bidder is included with this bid as Attachment "A", should the City require such.

ORACLE iSUPPLIER AND SOURCING

In addition to accepting 'hard copy' competitive sealed bids, proposals and qualifications, the City of Lakeland uses Oracle's iSupplier and Sourcing to administer the competitive solicitation process, including but not limited to soliciting quotes, sealed bids, proposals, and qualifications, issuing addenda, posting results and issuing notification of an intended decision. Bidders are strongly encouraged to familiarize themselves well in advance of their intention of submitting a proposal to ensure familiarity with the use of Oracle iSupplier and Sourcing. The City shall not be responsible for a Bidder's inability to submit a proposal by the end date and time for any reason, including issues arising from the use of Oracle iSupplier and Sourcing.

It is the sole responsibility of the Bidder to ensure that their response is submitted electronically through Oracle Sourcing, and hard copies reach the Purchasing Manager, City of Lakeland, Florida, 1140 E. Parker St., Lakeland, Florida 33801, no later than the time and date specified in this solicitation.

BID SUBMITTAL

An original and three (3) copies (collated in sets) of the bid form supplied by the City of Lakeland and all required bid submittal data shall be enclosed within a sealed envelope with the words, "**Sealed Bid No. 8332B – Supplemental Labor – Welding at McIntosh and Larsen Power Plant and Winston Generating Station**" and the Bidder's name and address clearly shown on the outside thereof. **Submittals received with less than the required total copies or not submitted on the City of Lakeland Bid Sheets may be disqualified as non-responsive.**

Mailed bids must be received in the office of the Purchasing Manager not later than the time set forth for bid opening. The City of Lakeland, Florida will not be responsible for any lost or late arriving bids sent via the U. S. Postal Service or other delivery services.

The City of Lakeland at its sole discretion reserves the right to waive technicalities or irregularities, to reject any or all bids, and/or to accept that bid which is in the best interest of the City. The award of this bid, if made, may be based on considerations other than total cost and may be awarded based on various considerations, including without limitation; Bidder's experience and/or qualifications, past experience, administrative cost, standardization, technical evaluation and oral and/or written presentations as required. The City reserves the right to accept all or part, or to decline the whole, and to award this bid to one (1) or more Bidders. There is no obligation to buy. The bid, if awarded, will be in the judgement of the City the most responsive to the City's needs. The City of Lakeland encourages the use of minority and women-owned businesses as subcontractors or in joint venture arrangements. Unless superseded by Federal or State laws or requirements, the City is authorized by Resolution No. 3634 to give preference to local persons, firms or corporations, in an amount of two percent (2%) not to exceed \$10,000 of the bid price.

City of Lakeland, Florida

Mark D. Raiford, CPPB
Purchasing Manager

BID SHEET:

SUPPLEMENTAL SKILLED LABOR - WELDING

At The

MCINTOSH and LARSEN POWER PLANTS

AND WINSTON GENERATING STATION

OCTOBER 31, 2018

BID NO. 8332B

THIS BID SHALL BE VALID FOR NINETY (90) DAYS FROM DATE OF OPENING

Company Name _____

Company Address _____

City _____ State _____ Zip _____

Telephone (_____) _____ Fax (_____) _____

E-Mail Address _____

The following Bid is in strict accordance with the **City of Lakeland Invitation to Bid No. 8332B, dated October 31, 2018, and all attachments as referenced therein:**

This Bid shall be **F.O.B. Delivered with Full Freight Allowed** and a **Total Firm Price** for all of the work outlined in the attached specifications.

A. Total Firm Bid Pricing for Supplemental Labor – Welding at McIntosh and Larsen Power Plant and Winston Generating Station:

See Break-Out Pricing on Following Bid Sheets

B. Please State the Name, Address and Telephone Number of the Branch Office that Serves the Lakeland, Florida Area where Technical Expertise is Available.

Name

Address

Telephone

C. Additional Materials over and above the written Scope of Work shall be billed at Cost Plus _____ Percent (%) and substantiated with paid invoices.

Note: This is not a time and materials contract. The cost plus material rate will only be utilized for materials purchased outside of the written scope of work and Owner approved in writing prior to ordering.

BID SHEET CONTINUED:
SUPPLEMENTAL SKILLED LABOR - WELDING

At The
MCINTOSH and LARSEN POWER PLANTS
AND WINSTON GENERATING STATION

OCTOBER 31, 2018

BID NO. 8332B

D. Please List All Anticipated Subcontractors:

<u>Name of Company</u>	<u>Address & Telephone</u>	<u>Type of Craft</u>
_____	_____	_____
_____	_____	_____
_____	_____	_____
_____	_____	_____
_____	_____	_____
_____	_____	_____
_____	_____	_____

E. Please List a Minimum of Three (3) Projects that Your Company Has Successfully Completed Within the Past Three (3) Years which are of Equal Size, Scope, Magnitude and Complexity as the Project to be Done for the City of Lakeland. This List shall be Specifically Prepared for this Bid Submittal and Should Include the Name of the Entity and the Name and Telephone Number of a Responsible Individual Qualified to Respond to Questions Concerning Your Company's Abilities, Costs, Schedules, etc. Note: Prior successful accomplishment of such equal work will be a consideration in determining whether the Bidder is qualified to perform the work specified herein.

<u>Company Name</u>	<u>Contact Person</u>	<u>Telephone Number</u>
1. _____	_____	_____
2. _____	_____	_____
3. _____	_____	_____

BID SHEET CONTINUED:

SUPPLEMENTAL SKILLED LABOR - WELDING

At The

MCINTOSH and LARSEN POWER PLANTS

AND WINSTON GENERATING STATION

OCTOBER 31, 2018

BID NO. 8332B

F. Schedule:

Work can be started in _____ calendar day(s) after Notification of Award.

Work can be completed in _____ calendar days after Commencement.

Terms of Payment Offered _____

Note: Payment shall be made within forty-five (45) days of receipt of invoice in accordance with Florida Statute §218.74, the Local Government Prompt Payment Act.

“I hereby certify that I understand and am aware that the City of Lakeland at its sole discretion reserves the right to waive technicalities or irregularities, to reject any or all bids, and/or to accept that bid which is in the best interest of the City. The award of this bid, if made, may be based on considerations other than total cost and may be awarded based on various considerations, including without limitation; Bidder’s experience and/or qualifications, past experience, administration cost, standardization, technical evaluation and oral and/or written presentations as required. The City reserves the right to accept all or part, or to decline the whole, and to award this bid to one (1) or more Bidders. There is no obligation to buy. The bid, if awarded, will be in the judgement of the City the most responsive to the City’s needs. The City of Lakeland encourages the use of minority and women-owned businesses as subcontractors or in joint venture arrangements. Unless superseded by Federal or State laws or requirements, the City is authorized by Resolution No. 3634 to give preference to local persons, firms or corporations, in an amount of two percent (2%) not to exceed \$10,000 of the bid price. Any bidder sent three (3) or more invitations to bid and fails to respond may be removed from the City bid list.”

Company Name

Authorized Signature

Date Signed

**Name of Contact for Questions
(Please Print or Type)**

Telephone No. of Contact

Break-Out Pricing for Specification PBM 19002
Annual Supplemental Labor - Welding

1. Normal operation (non-outage) Straight Time cost per Tube Welder, as defined in Specification PBM 19002, item 2.4(b)

\$ _____

2. Normal operation (non-outage) Straight Time cost per Plate Welder as defined in Specification PBM 19002, item 2.4(b)

\$ _____

3. Normal operation (non-outage) Straight Time cost per Apprentice (Skilled Welder Helper)

\$ _____

4. Normal operation (non-outage) Overtime cost per Tube Welder

\$ _____

5. Normal operation (non-outage) Overtime cost per Plate Welder

\$ _____

6. Normal operation (non-outage) Overtime cost per Apprentice

\$ _____

7. Outage Straight Time cost per Tube Welder

\$ _____

8. Outage Straight Time cost per Plate Welder

\$ _____

9. Outage Straight Time cost per Apprentice

\$ _____

10. Outage Overtime cost per Tube Welder

\$ _____

11. Outage Overtime cost per Plate Welder

\$ _____

Break-Out Pricing for Specification PBM 19002
Annual Supplemental Labor – Welding (cont.)

12. Outage Overtime cost per Apprentice

\$ _____

13. Normal operation 8-hour cost per two-man Structural Crew (Plate Welder, Apprentice)

\$ _____

14. Normal operation 10-hour cost per two-man Structural Crew (Plate Welder, Apprentice)

\$ _____

15. Outage 8-hour cost per two-man Structural Crew (Plate Welder, Apprentice)

\$ _____

16. Outage 10-hour cost per two-man Structural Crew (Plate Welder, Apprentice)

\$ _____

17. Normal operation ST hourly cost for Safety Watch

\$ _____

18. Normal operation OT hourly cost for Safety Watch

\$ _____

19. Outage ST hourly cost per Safety Watch

\$ _____

20. Outage OT hourly cost per Safety Watch

\$ _____

21. Mark-up percentage rate for materials more than \$300.00 per job

\$ _____

Break-Out Pricing for Specification PBM 19002
Annual Supplemental Labor – Welding (cont.)

22. Mark-up percentage rate for equipment rentals

\$ _____

23. Per Diem cost

\$ _____

24. Firm Cost for six-journeyman Structural Welder presence during 30-day Outage, per conditions set forth in Specification item 2.4(q) – INCLUDING ALL TOOLS, VEHICLES & EQUIPMENT

\$ _____

SPECIFICATION WITH TERMS AND CONDITIONS

SPECIFICATION NO. PBM 19002

FOR

SUPPLEMENTAL SKILLED LABOR

WELDING

AT THE

MCINTOSH AND LARSEN POWER PLANTS

AND WINSTON GENERATING STATION

PREPARED BY:

OUTAGE AND PROJECTS

DEPARTMENT OF ELECTRIC UTILITIES

CITY OF LAKELAND

LOG OF REVISIONS

REV. NO.	DESCRIPTION OF CHANGES	DATE	APPROVED BY
A	Original Issued for Review	09/20/2018	MKB
B	Reviewed and approved	09/21/2018	CK
C	Reviewed and approved	09/24/2018	JB
D	Issued to Contracts Dept.	09/24/2018	MKB
E	Issued to Purchasing	09/28/2018	MKB

Contents

SECTION 1.0 DEFINITIONS.....	5
1.1 General Definitions	5
SECTION 2.0 DESCRIPTION OF WORK	7
2.1 Scope.....	7
2.2 Contract Award	7
2.3 Schedule.....	8
2.3.1 OWNER’s Right to Terminate Agreement.....	8
2.4 Contract Workers.....	8
2.5 Bid Scope.....	8
SECTION 3.0 TECHNICAL REQUIREMENTS	9
3.1 Workmanship.....	9
3.2 Work Time.....	9
3.3 General Procedures for Supplemental WELDING Maintenance Labor Needs	10
3.4 Materials and Equipment.....	10
3.5 Personnel Qualifications	11
3.5.1 GENERAL:	11
3.5.2 Previous Qualifications:	11
3.5.3 Renewal of Qualification.....	11
3.5.4 Unsuitable Personnel	12
3.7 Outage Needs.....	12
SECTION 4.0 DEFINITION OF RESPONSIBILITIES.....	12
4.1 CONTRACTOR’S Responsibilities	12
SECTION 6.0 BID PREPARATION	15
6.1 Bidder’s Qualifications.....	15
6.2 Bid Instructions.....	15
6.3 Bid Addenda	16
6.4 Placement of Order	16
6.5 Post Bid Meeting	16
6.6 Compatibility with Jobsite Conditions	16
6.7 CONTRACTOR'S State License.....	17
6.8 Acceptance of Bid.....	17
SECTION 7.0 GENERAL PROVISIONS	17

7.1 Form of Agreement	17
7.2 Change Orders.....	17
7.3 Project Schedules	17
7.4 Subcontractors	18
7.5 Back-Charges	18
7.6 Payment	18
7.7 Invoices.....	19
7.8 Substitutions.....	20
7.9 Performance Guarantee and Equipment Warranty	20
7.10 CONTRACTOR'S Obligations.....	20
7.11 CONTRACTOR'S Cooperation.....	21
7.12 Assignment.....	21
7.13 Codes and Regulations	21
7.14 OWNER'S Representative	22
7.15 Inspection	22
7.16 Fire Protection.....	22
7.17 Site Clean Up	22
7.18 Plant Location and Access	23
7.19 Entrance Gate and Parking	23
7.20 Operations Interference	23
7.21 Royalties and Patents	23
7.22 Damages to Asbestos Designated Equipment	24
7.23 Licenses and Insurance.....	24
7.24 Default.....	24
7.25 Termination for Convenience.....	24
7.26 Delay.....	24
7.27 Force Majeure	25
7.28 Claims and Contract Negotiation.....	25
7.29 Notice	25
7.30 Jurisdiction, Venue and Governing Law.....	26
7.31 Public Records	26
SECTION 8.0 SPECIAL REQUIREMENTS	27
8.0 Right to Offset	27

ATTACHMENT 1..... 28
ATTACHMENT 2..... 29
ATTACHMENT 3..... 30
ATTACHMENT 4..... 32
ATTACHMENT 5..... 33
ATTACHMENT 6..... 34
ATTACHMENT 7..... 36

SECTION 1.0 DEFINITIONS

1.1 General Definitions

Wherever used in this Specification or in the other Contract Documents, the following terms shall have the meanings indicated which shall be applicable of both the singular and plural thereof:

- a. Addendum - Changes to the original Specification covering the Work to be performed.
- b. Approved - Approved, acceptable, considered necessary, satisfactory, or words of similar meaning shall mean approved, acceptable, considered necessary or satisfactory to or by the OWNER
- c. Bidder – Bidder shall be the person, persons, partnership, company, or corporation responding to the OWNER's Request for Proposal in accordance with the OWNER's established policies and procedures.
- d. Change Order - A written order to CONTRACTOR signed by the OWNER authorizing an addition, deletion, or revision in the Work, or an adjustment in the Contract Price or the Contract Time issued after execution of the Contract.
- e. Contract – Contract shall mean the definitive final written agreement between OWNER and CONTRACTOR incorporating the covenants, terms, conditions, and technical requirements of this Specification.
- f. Contract Documents - The Contract Documents shall mean, collectively, the OWNER's RFP or Invitation to Bid, the Contract, this Specification, OWNER approved addendum and exceptions, the Public Construction Bond, the OWNER's Purchase Order and CONTRACTOR's proposal which are intended to be complementary, and what is required by any one of them shall be as binding as if required by all. In the event of a conflict, the order of hierarchy shall be the order listed in the finalized version of the Contract or on the Purchase Order.
- g. Contract Time - The total number of calendar days, and any completion dates for phases or segments of the Contract Work shown on the Final Schedule to be completed by the parties.
- h. Contract Price - The total monies, payable to CONTRACTOR under terms of the Contract.
- i. CONTRACTOR - The person, persons, partnership, company, or corporation undertaking the performance of the Work required by the Contract.
- j. Day – A calendar day or any fraction thereof.
- k. Equal - The words "or equal" used in connection with materials, products, or equipment designated by manufacturer's names, trade names or catalog numbers are intended to establish a standard. Other materials, products, or equipment meeting or exceeding the established standard may be used provided that their equivalency has been demonstrated to the satisfaction of the OWNER and that written approval of their use has been obtained.
- l. Field Order - A written order signed by the OWNER and CONTRACTOR as an agreement of clarification of the Contract and not any adjustment in the Contract Price or Time.

- m. "Hazardous Materials" shall mean those materials included within the definitions of "hazardous substances", "hazardous materials", "toxic substances", "contaminants" or "hazardous wastes" in the Comprehensive Environmental Response, Compensation and Liability Act of 1980, as amended (42 USC Sections 9601, et seq.); the Hazardous Materials Transportation Act, as amended (49 USC Sections 1801, et seq.); the Resource Conservation and Recovery Act, as amended (42 USC Sections 9601, et seq.); the Toxic Substance Control Act as amended (15 USC Section 2601 et seq.); the Environmental Protection Act, R.S.O. 1990, C.E. 19; the Environmental Protection Act, S.C. 1991 c. 15.3, as amended; and in any of the regulations adopted, published, and promulgated pursuant to said laws, or in any other Laws and Regulations.
- n. Installation - Installation includes in addition to actual installation, all unloading, warehouse handling, rigging and hoisting, and furnishing of all tools, equipment and materials required to handle and install the Work, except as otherwise specified in the Contract.
- o. Invitation to Bid – Invitation to Bid shall be the Request for Proposal (RFP) or other notice duly issued by the City of Lakeland's Purchasing Department incorporating the Specification and other documents as may be required by municipal code or charter or by Florida statutes to solicit competitive prices for labor, material, and services.
- p. Manufacturer - An individual, firm or corporation who is furnishing material or equipment to either the OWNER or CONTRACTOR or both.
- q. By Others - Refers to labor or materials to be furnished by the OWNER, by a CONTRACTOR or subcontractor other than CONTRACTOR
- r. OWNER - The City of Lakeland (aka COL), or its authorized representatives, successors or assigns.
- s. Project - The entire construction and Work to be performed as provided in the Contract.
- t. Provisional Acceptance – Provisional Acceptance shall occur upon successful completion of all Work except for; (i) completion of the punch list, (ii) delivery of as-builts and, (iii) completion of the applicable Performance Test(s).
- u. Purchase Order (PO) – A Work authorization document issued by the OWNER'S Purchasing Department with the words "Purchase Order" clearly marked on the top right corner, a PO number used for reference shown on the front, a description of the Work or a listing of the applicable Contract Documents, an authorized OWNER signature and stating the amount of lawfully authorized funds. Purchase Orders are the only documents that authorize payment of changes to the total amount authorized on the Contract.
- v. Schedule – the agreed upon sequence of activities with start and finish dates including logical relationships of activities, deliverables, and milestones agreed to at issuance of Purchase Order
- w. Shop Drawings - All Manufacturer's and CONTRACTOR's drawings, diagrams, illustrations, brochures, schedules, and other data which illustrate the details of the equipment, material and Work to be furnished for the Project.
- x. Specification – The covenants, terms, conditions, and technical requirements contained in this written document titled, Specification PBM 19002, For Supplemental Skilled Welding Labor.
- y. Work – All the activities as generally described in the scope sections (typically sections 2 and 3) of the Specification.

- z. Worksite – Either or both sites where the Work is to be performed, namely the City of Lakeland’s McIntosh Power Plant located at 3030 East Lake Parker Drive, and the Larsen Power Plant, located at 2002 East Highway 92, in Lakeland, Florida. The terms “Jobsite” and “Worksite” may be used interchangeably.
- aa. Deg. F – stands for temperature degrees in Fahrenheit

SECTION 2.0 DESCRIPTION OF WORK

2.1 Scope

The CITY OF LAKE LAND is seeking bids from qualified Industrial Maintenance CONTRACTORS to supply highly skilled and certified Industrial Welders (hereafter referred to as “WELDER”, “TUBE WELDER” or “PLATE WELDER”) on an as-needed basis in strict accordance with the terms and conditions set forth in this Specification. Contract WELDER shall be utilized to assist OWNER in supplementing its existing workforce during planned Outages, and otherwise as OWNER sees fit, and will be required to perform journey level, highly skilled journey level work, performing advanced welding procedures. Work involves the performance of a variety of tasks in high pressure code welds, alloy welds, carbon steel welds, and similar welds of an advanced nature, and requiring a high degree of technical knowledge, skill and precision. Duties include the mechanical maintenance of high pressure steam Power Plant equipment, and the limited supervision on subordinates. Workers are assigned to specific jobs by oral and/or written instructions, which may include sketches and blueprints. This Work is usually performed in two-man teams, with guidance or assistance given by OWNER’S Welding foreman or journeymen on difficult and complex jobs. Work is inspected upon completion. Contract Workers’ duties and requirements are at minimum based on OWNER’S “Plant Welder II” job description, see ATTACHMENT 3.

In addition to the specific duties and qualifications listed in OWNER’S job description, COL requires that for reasons of safety and as a matter of Quality Control, CONTRACTOR’S WELDERS

- a. Are fully capable of understanding instructions, written and verbal, in the English language
- b. Are fully capable of relaying findings, recommendations and failure reports, verbally and in writing, in the English language
- c. Have four (4) years minimum experience working in large industrial facilities

2.2 Contract Award

- a. The Annual Supplemental Labor Agreement shall be referred to as the Welding Maintenance Contract (hereinafter, “Contract” or “Agreement”). At the time of Contract Award, OWNER may elect to award Contract services to multiple Bidders to ensure resource availability:
 - i. OWNER will offer first right of refusal to lowest and most responsive evaluated Bidder; if this Bidder is unable to provide needed manpower, OWNER will request personnel from second awarded Bidder
 - ii. For specific projects, OWNER will request Time and Material (T&M) pricing from multiple Contract-Awarded Bidders
 - iii. OWNER reserves the right to seek services from alternate sources IF Contract-Awarded party(ies) are unable to meet OWNER’S needs

- b. For T&M jobs, the labor and material portions of the rates shall be all inclusive, having no separate charges for: insurance costs, office overhead costs, field overhead costs, transportation and delivery charges, material costs, payroll taxes, profit, sundry charges (including sub-contracts if required), removal/disposal of old material, and everyday equipment / tool rental charges (clarified in Section 4.1, CONTRACTOR's Responsibilities). Additional charges will not be allowed

2.3 Schedule

CONTRACT shall become effective upon execution by all parties, and shall remain in effect for an initial three (3) year term, unless terminated as provided for herein. The initial term may be extended by two (2) additional one (1) year terms by agreement of parties. Under no circumstances will the term of the CONTRACT exceed the date of September 30th, 2023.

2.3.1 OWNER's Right to Terminate Agreement

OWNER reserves the right terminate this agreement with any or all parties if

- a. CONTRACTOR fails to provide qualified workers as requested by OWNER
- b. CONTRACTOR fails to replace workers rejected by OWNER within two (2) business days
- c. CONTRACTOR falsifies certifications, provides test answers to prospective employees, or in any other way attempts to mislead OWNER regarding experience, abilities, qualifications, and/or certifications of workers

2.4 Contract Workers

- a. CONTRACTOR shall provide Contract Workers in the numbers required by OWNER to perform assigned tasks and Work on a standard (ST) and/or overtime (OT) basis.
- b. Individuals furnished by CONTRACTOR to satisfy the terms of this Specification shall be referred to as "TUBE WELDER", and "PLATE WELDER", the term "TUBE WELDER" being understood to mean that any TUBE WELDER offered by CONTRACTOR is certified to perform high pressure code welds, alloy welds, dissimilar metal welds, welding of tubes and pipes and plate of different wall thicknesses, and all manner of complex and difficult welds, including mirror welds, and that any PLATE WELDER is a qualified structural welder, or ironworker
- c. The term "WELDER" shall refer to any qualified welder generically, including TUBE WELDERS, PLATE WELDERS, and skilled welding Apprentices
- d. All safety training and certifications (including, without limitation, respirator training, confined space, PSM awareness, arsenic awareness, first aid, etc.) required by the OWNER shall be provided by the CONTRACTOR at the CONTRACTOR'S expense. The certifications shall be in place prior to WELDERS reporting to the Jobsite, and CONTRATOR shall provide copies of these certifications to OWNER'S Representative prior to the commencement of work
- e. WELDERS shall report to, and work under the direction and supervision of OWNER'S Welding Maintenance staff

2.5 Bid Scope

For the OWNER to evaluate the lowest qualified bid to this Specification, the Bidder will submit:

- a. Each and separate normal-operation ST and OT hourly cost per TUBE WELDER and PLATE WELDER
- b. Normal-operation ST and OT hourly cost per Apprentice (Skilled Welder Helper)
- c. Each and separate Outage ST and OT hourly cost per TUBE WELDER and PLATE WELDER
- d. Outage ST and OT hourly cost per Apprentice
- e. Normal-operation 8-hour cost per two-man structural crew (PLATE WELDER, and Apprentice; welding machine and truck)
- f. Normal-operation 10-hour day cost two-man structural crew (PLATE WELDER, and Apprentice; welding machine and truck)
- g. Outage 8-hour cost per two-man structural crew (PLATE WELDER, and Apprentice; welding machine and truck)
- h. Outage 10-hour day cost per two-man structural crew (PLATE WELDER, and Apprentice; welding machine and truck)
- i. Items 2.4(e) through 2.4(h) for a three-man TUBE crew (two (2) TUBE WELDERS and Apprentice; welding machine and truck)
- j. Mark-up percentage rate for materials more than \$300.00 per job
- k. Mark-up percentage rate for equipment rentals
- l. Per Diem cost
- m. Support Costs per crew-size, i.e., if at six men CONTRACTOR requires a Safety Presence; at ten-men, a Safety Presence and a tool trailer, each increase in cost per increase in crew size shall be broken out as its own line-item
 - i. EXAMPLE 1: Crew of 6 requires 1 Safety Person @ \$85.00/hr ST, \$130.00 OT
 - ii. EXAMPLE 2: Crew of 10 requires Field Supervisor @ \$78.00/hr ST, \$115.00 OT, plus Tool Trailer @ \$350.00/week, 1 week minimum, therefore crew of 10 would add cost of one Safety Person, plus one Supervisor, plus one Tool Trailer
- n. Firm Cost for six-journeyman PLATE WELDER presence during Outage, given the following conditions:
 - i. Outage is thirty working days (actual Outages are of different durations – see ATTACHMENT 4)
 - ii. Working hours are 0600 – 1630, Monday through Saturday
 - iii. CONTRACTOR’S Apprentices, Fire-Watch or Hole-Watch are not counted among PLATE WELDERS i.e., CONTRACTOR’S on-site presence will be 8, for bidding purposes
 - iv. Cost will include all tools, equipment, and vehicles
 - v. All associated Support Cost, as defined above in item 2.4(l)

SECTION 3.0 TECHNICAL REQUIREMENTS

3.1 Workmanship

- a. OSHA guidelines must be met, as well as City of Lakeland safety guidelines
- b. CONTRACTOR’S on-site Supervisor must be designated “competent person” as defined in 29 CFR 1926.450. Documentation of this may be requested by OWNER at any time

3.2 Work Time

Normal working hours of CONTRACT labor will be:

- a. Monday through Thursday, 0600 – 1630, unless directed to b.
- b. Tuesday through Friday, 0600 – 1630, except during Outages
- c. OUTAGE schedule will be either:
 - i. a. or b. above, or
 - ii. Monday through Saturday, 0600 – 1630, or
 - iii. Monday through Saturday, 0600 – 1830
- d. CONTRACTOR shall not work holidays unless directed by the OWNER
- e. No CONTRACTOR personnel may work a single shift exceeding fourteen (14) hours
- f. Work hours are subject to change: CONTRACTOR will receive email notification of schedule changes a minimum of 2 weekdays before the changes are to take effect
- g. On occasion, work will need to be done other than “straight time” hours. On these occasions, the invoicing will be calculated by a multiplier factor used to adjust unit prices. This factor shall be supplied by the Bidder in his/her bid. Overtime work must be approved by OWNER prior to the work starting. Non-approved overtime charges will not be paid
- h. CONTRACTOR will provide billing rates for straight time, overtime (or premium time), holiday time, and per diem cost

3.3 General Procedures for Supplemental WELDING Maintenance Labor Needs

- a. Any authorized representative of OWNER may initiate a request for CONTRACTOR personnel, however CONTRACTOR shall not mobilize staff until OWNER’S representative has requested staff via email, or other formal written means
- b. OWNER’S authorized Representative will communicate directly with the CONTRACTOR to convey his/her specific manpower requirements (crew size, time duration, etc.)
- c. A copy of the OWNERS work order will also be issued to CONTRACTOR’S representative. CONTRACTOR shall reference OWNERS work order number on all correspondence, time sheets, and invoicing
- d. Notification to OWNER’S representative must be made each time any CONTRACTOR employee arrives at and leaves OWNER’S property
- e. Duplicate timesheets must be maintained by OWNER and CONTRACTOR, and the billing must directly refer to and agree with documentation

3.4 Materials and Equipment

- a. CONTRACTOR must use only OSHA approved materials and equipment
- b. When applicable, CONTRACTOR shall provide, for PRIOR approval, all SDS for any coatings, solvents, lubricants, and any other potentially harmful or flammable materials to be brought on-site
- c. CONTRACTOR shall be responsible for the proper storage and disposal of all materials referenced in item 3.5.b
- d. CONTRACT WELDERS shall immediately contain, clean-up, and report to COL representative any spills
- e. At no additional cost to OWNER, CONTRACTOR shall ensure that WELDERS and Apprentices keep and maintain on-site, whether in gang-boxes, or OWNER-approved trailer:
 - i. OWNER approved Welding Hood
 - ii. Chipping Hammer
 - iii. Wire brush(es)

- iv. Welding Sleeves, jacket and leathers
 - v. Welding whip
 - vi. Hand-held grinders and wire-wheels
 - vii. Extension cord
 - viii. Come-alongs, to 1-1/2 ton
 - ix. Fire extinguisher
 - x. Any safety equipment at cost < \$300.00
 - xi. Torch Sets
 - xii. All Employee PPE (i.e., safety glasses, face shields, gloves, harnesses and lanyards, ear-plugs, dust masks, respirators, etc.)
 - xiii. Tool consumables, such as grinding wheel attachments, fire extinguishers, etc.
- f. CONTRACT WELDERS shall clean and return any tools borrowed from OWNER'S tool room at the end of each shift or upon completion of task, whichever comes first

3.5 Personnel Qualifications

3.5.1 GENERAL:

CONTRACTOR shall provide competent, qualified personnel for the workmanship and services associated with this Specification

- a. CONTRACTOR shall warrant that all due diligence in pre-employment screening has been conducted by CONTRACTOR, including reference checks, drug-testing, employment, education and criminal background verification
- b. CONTRACT WELDERS should meet the minimum qualifications of the attached Job Description

3.5.2 Previous Qualifications:

Welding procedures and WELDERS previously qualified by test may be accepted for the work described in this Specification, provided

- a. CONTRACTOR shall submit 1023-G certification for each TUBE WELDER
 - i. CONTRACTOR may use the attached OWNER'S procedure (see ATTACHMENT 6) to test WELDERS
 - ii. Other procedures and procedure qualifications test records may be acceptable, but must be approved by OWNER'S Welding and Mechanical Maintenance supervisory staff
- b. CONTRACTOR shall submit 1017-G certification, or most up-to-date equivalent, including procedures for each PLATE WELDER
- c. Prior testing will have been approved by an OWNER approved testing laboratory or technical consultant, or by CONTRACTOR'S approved quality control organization

3.5.3 Renewal of Qualification

Requalification of WELDER shall be required under one or any combination of the following conditions:

- a. WELDER has not used the specific welding procedure called for in a period of or more than three (3) months; the period may be extended to six (6) months if WELDER has been employed continuously on an equivalent or very similar weld procedure
- b. There is a specific reason to question WELDER'S ability to perform weld procedure to meet OWNER requirements

- c. WELDER was qualified under an employer other than CONTRACTOR, and no qualification test has been taken within twelve months; requalification under this condition need only be made on a single test joint, pipe of any thickness, position, or material to re-establish qualification for any thickness, position, or material for which welder was most recently qualified

3.5.4 Unsuitable Personnel

At OWNER'S sole discretion, WELDERS may be subjected to re-testing by OWNER'S Welding Maintenance staff

- a. Expenses borne by OWNER for WELDERS failing any test or re-test administered by OWNER may be offset against CONTRACTOR'S account
- b. Expenses borne by OWNER for WELDERS deemed, in the sole opinion of OWNER, unsuitable, and who are rejected within the first three (3) full days of work may be offset against CONTRACTOR'S account
- c. OWNER reserves the right to reject any WELDER for any or no reason, at any time
- d. CONTRACTOR shall replace any rejected personnel within two (2) business days of OWNER notification
- e. Failure by CONTRACTOR to provide qualified personnel shall be considered a material breach of Contract

3.7 Outage Needs

Lakeland Electric's McIntosh Unit No. 3 will enter its Spring Outage of 2019 on February 9th, and remain in Outage until March 25th. CONTRACTOR will provide a ten (10) man team of four (4) TUBE WELDERS, four (4) PLATE WELDERS, and two (2) Apprentices to assist OWNER'S Welding Maintenance staff. CONTRACTOR will provide and stage all necessary ancillary personnel, all tooling and hardware to support this team. To this end:

- a. CONTRACTOR shall submit a list of twenty (20) candidate workers, no less than thirty days prior to Unit shutdown on February 8th, along with their:
 - i. Qualifications and procedures
 - ii. Relevant certifications and verification of safety training
 - iii. Summary of employment history and industrial mechanical experience
- b. CONTRACTOR shall stage all necessary support materials, vehicles and equipment no less than ten days prior to Unit shutdown in area designated by OWNER
- c. Work hours are to be determined
- d. OWNER'S does not guarantee any particular daily work schedule, for any duration
- e. WELDERS working under the supervision of, and with OWNER'S Mechanical Maintenance staff shall take morning, lunch, and afternoon breaks with their COL Work group

SECTION 4.0 DEFINITION OF RESPONSIBILITIES

4.1 CONTRACTOR'S Responsibilities

- a. CONTRACTOR must keep and maintain a home office/shop within seventy (70) miles of OWNER'S property
- b. The CONTRACTOR shall provide necessary qualified personnel to perform work specified by the OWNER

- c. The CONTRACTOR shall assume full responsibility for their employees' conduct while on OWNER'S property
- d. The CONTRACTOR shall not permit any alcoholic beverages or illegal drugs on OWNER'S property. Any person showing the most minor symptoms of alcohol or drug use shall be immediately removed from OWNER'S property and shall not be allowed to return. Likewise, the CONTRACTOR shall not permit any firearms to be brought on OWNER'S property
- e. The CONTRACTOR shall provide materials and installation of all required heat retention covering
- f. The CONTRACTOR shall provide all small hand and power tools necessary to perform his work including screw guns, drills, etc.
- g. The CONTRACTOR shall provide, when needed, general purpose slings, rigging equipment, including chain hoist, buck hoist, tools, heating and burning equipment, precision measuring tools, and hand tools.
- h. The CONTRACTOR shall provide a lockable tool box/trailer to store the CONTRACTOR's tools, materials, and equipment in
- i. The CONTRACTOR shall provide protection of all power plant equipment adjacent to work area (above, below, beside). The CONTRACTOR shall provide temporary weather protection materials (lumber, plastic sheeting, tarps, etc.) and erection of such materials as required
- j. The CONTRACTOR shall provide all required office facilities, tool storage facilities, etc.
- k. The CONTRACTOR shall furnish its own sanitary facilities, water cans, and ice
- l. The CONTRACTOR will provide an overhead crane (include operator), as needed
- m. The CONTRACTOR shall furnish fire extinguishers, as needed
- n. The CONTRACTOR shall provide own safety equipment and PPE
- o. The CONTRACTOR shall perform work in a clean and orderly manner using safe work practices in compliance with OSHA
- p. The CONTRACTOR shall be responsible for any preventative measures to contain any potential release or spill of environmentally hazardous material and petroleum products that may result from performing the contracted work
 - i. In the event of a release or spill of environmentally hazardous material and/or petroleum products by CONTRACTOR or any event observed by CONTRACTOR, the CONTRACTOR shall notify the plant operations Control Room/PPS/O at (863) 834-6681, and OWNER'S Environmental Programs Coordinator, David Watson, at (863) 834-6607
 - ii. CONTRACTOR shall be responsible for any cleanup, removal, and disposal of said materials or products resulting from performing contracted work and CONTRACTOR shall provide copies of all waste generation disposal manifests, disposal site records, transport records, certificate of disposal, etc., to the City of Lakeland

- iii. Where there is the potential for a release or spill of environmentally hazardous material and/or petroleum products that could result from performing contracted work, the City of Lakeland Risk Management Department will determine CONTRACTOR insurance requirements and specify those requirements within the bid or contract documents
- q. THE CONTRACTOR SHALL PROVIDE THE OWNER COPIES OF MSDS FOR ALL CHEMICALS THAT ARE TO BE USED ON THE JOBSITE PRIOR TO BRINGING THEM ONSITE. CONTRACTOR SHALL ALSO SUPPLY THE OWNER WITH AFFIDAVIT THAT ALL CONTRACTOR'S EMPLOYEES AND SUBCONTRACTORS HAVE RECEIVED TOXIC SUBSTANCE/RIGHT TO KNOW TRAINING
- r. The CONTRACTOR shall maintain a mobile communication device for the CONTRACTOR'S on-site supervisor for daily and emergency communications. The CONTRACTOR's on-site supervisor will be required to be available for communication on a 24 hour, 7 Day a week basis
- s. The CONTRACTOR shall furnish Bid, Public Construction bond, and insurance in accordance with terms specified in the Invitation to Bid
- t. THE CONTRACTOR SHALL PROVIDE THE OWNER WITH AN AFFIDAVIT THAT ALL CONTRACT WORKERS HAVE RECEIVED TOXIC SUBSTANCE/ RIGHT TO KNOW TRAINING.
- u. The CONTRACTOR shall submit to the OWNER the Contractor's Training Package for confined space, PSM awareness (ammonia), welders' arsenic compliance, respirator training, safety harness training and other safety programs.
- v. The CONTRACTOR is solely responsible for ensuring its compliance with applicable laws including the Immigration Reform and Control Act of 1986 ("IRCA"). The CONTRACTOR will comply fully with the recordkeeping and other requirements of the IRCA including, without limitation, Form I-9 requirements and will furnish such documentation to the OWNER immediately upon request. The CONTRACTOR will provide the OWNER with only those Contract Workers whom the CONTRACTOR has confirmed are legally eligible to work in the United States and for whom all records have been obtained and maintained as required under the IRCA.
- w. The CONTRACTOR agrees that it will comply with all laws and regulations applicable to its performance of the Work and to the OWNER'S employees. As the OWNER is an affirmative action and equal opportunity employer, the CONTRACTOR shall not discriminate in the provision of the Work to the OWNER based on race, color, national origin, religion, sex, marital status, disability, sexual orientation, age or any other legally proscribed criteria. The CONTRACTOR shall comply with all applicable local, state and federal labor and employment laws, regulations and ordinances, including, but not limited to those prohibiting discrimination, harassment and retaliation and wage and hour laws.
- x. The CONTRACTOR shall maintain adequate records and supporting documentation applicable to this Contract including, but not limited to, employment records relating to the CONTRACTOR'S application process, training provided, benefits offered to CONTRACTOR'S employees and agents, information from background checks, time and payroll records, I-9 forms, documentation demonstrating compliance with applicable employment laws, and the insurance requirements set forth herein. Said records and documentation shall be retained by the CONTRACTOR for a minimum of three (3) years from the date of termination of the Contract. The OWNER and its authorized agents shall have the right to audit and conduct on-site review at CONTRACTOR'S offices, inspect and copy all such records and documentation as often as the

OWNER deems necessary during the period of this Award and during the period of three (3) years thereafter. The three (3) year period will be extended until audit findings are issued if an audit is initiated during the three (3) year period. Such activity shall be conducted only during normal business hours. The OWNER, during this period shall also have the right to obtain a copy of and otherwise inspect any audit made at the direction of the CONTRACTOR as concerns the aforesaid records and documentation.

SECTION 6.0 BID PREPARATION

6.1 Bidder's Qualifications

An award for Work will be made only to a responsive, responsible Bidder, in a financial position and with the organizational ability to do the work specified herein and qualified by experience. The Bidder shall submit adequate evidence of their ability to fulfill contracts such as the one being bid. Specific qualification requirements are noted in paragraph 5.2.b. (i-xxi).

6.2 Bid Instructions

- a. The bid may not be given full consideration unless it is firm and includes all the information requested in this Specification, and on the OWNER'S Invitation to Bid. A satisfactory explanation must be given for not complying with the bid instructions. Failure to provide all applicable information, or to submit bid by due date, may be cause for disqualification as non-responsive.
- b. To allow the OWNER the opportunity to properly evaluate the Bids, and to become the successful bidder, Bidders must be able to provide a proven ability to perform the type of work described herein. Bidders should include at the time of bid submittal, a minimum of:
 - i. A list of a minimum of three (3) jobs that the Bidder has performed within the past three (3) years which are of equal size, scope, magnitude and complexity as the type of work to be done for the OWNER. The list should include the name of the entity, name and phone number of a responsible individual qualified to respond to questions concerning the Bidder's abilities, costs, schedules, etc. Prior successful accomplishment of such equal work will be a consideration in determining whether the Bidder is qualified to perform the Work.
 - ii. Supervisory and staffing capabilities with resumes of supervisory personnel planned for subject work and the number and classification of personnel required per shift.
 - iii. A total firm price for all work and materials outlined in all sections of this Specification. The Bid shall also include unit prices where indicated. It must be clearly understood that this is a total firm price bid for work defined in this specification. Only unexpected or unknown major or extensive repair will be negotiable for an increase in compensation for services rendered using an agreed upon total firm price or unit prices and must be agreed to in writing by the OWNER.
 - iv. A breakdown for response times to include emergency maintenance / repair work to restore system.
 - v. Terms of payment for work completed on the Jobsite which will produce the lowest overall total price on a delivered basis for all work and material furnished, subject to any specified final payment provisions.
 - vi. Copy of typical final report provided to clients.

- vii. Breakdown of hourly rates for all personnel classifications involved to be utilized in determining extra cost of any work not covered by this specification and agreed to in writing by the OWNER.
- viii. A breakdown for materials, labor cost and estimated duration of contract. The OWNER requires that separate invoices be submitted for labor and material.
- ix. A breakdown of **additional** insurance expenses the bidder will incur if required to meet the insurance limits of this specification.
- x. Statement of performance guarantee, if any.
- xi. Air, water, steam and utility requirements, where applicable.
- xii. Complete list of equipment included with system, giving model number and name and location of manufacturer.
- xiii. Operating performance or efficiency curves, in triplicate.
- xiv. Descriptive literature, bulletins and other data covering system or equipment proposed.
- xv. Exceptions to OWNER's inquiry, drawings and Specification, if any, must be submitted with full explanation.
- xvi. Statement that equipment and/or system proposed meets with all local or state codes, laws and requirements for operation and installation in the state to be used.
- xvii. Bidders are requested to show earliest possible delivery date, expressed in calendar weeks, after receipt of purchase order.
- xviii. Bidder must complete all required vendor data as shown in this Specification, and data sheets if applicable, and return with the bid.
- xix. Bidder must arrange for separate billing by the freight carrier to the OWNER for the freight charges with the freight "FOB destination".
- xx. Bidder will ship the material "FOB destination" and pay the freight to the freight carrier.
- xxi. The Bidder shall specify the name of the repair facility, if any; that is intended to be used in performance of the Work.

6.3 Bid Addenda

The OWNER may, during the bidding period, advise all Bidders by Addenda of additions, deletions, or alterations in the specifications. All Addenda shall be acknowledged in the bids. The Addenda shall become a part of the Specifications as if originally included therein.

6.4 Placement of Order

In the event an order results from the bid, it shall be placed with the office of the company which services the Lakeland, Florida area and will be expected and required from the nearest service and/or sales office, and all operating difficulties that arise shall be handled locally by the CONTRACTOR. The bid should state the name and address of the branch office serving the Lakeland area.

6.5 Post Bid Meeting

The successful Bidder shall submit all required documents to the OWNER within ten (10) days of the notification that Bidder was successful and meet with the OWNER's representative to discuss the Scope of Work and the best ways of implementing the work. The project manager named by the Bidder in the Bid should attend this meeting.

6.6 Compatibility with Jobsite Conditions

The Bidder shall acquaint itself and be familiar with the labor practices, conditions, and procedures established and accepted in the building and construction trades prevailing in the project area.

6.7 CONTRACTOR'S State License

The Bidder shall include in the bid qualification their CONTRACTOR's Registration Number as required by Florida Statute Chapter 633.

6.8 Acceptance of Bid

The right is reserved by the OWNER to reject any or all bids. The OWNER does not obligate itself to accept the lowest cost or any other bid. The OWNER reserves the right to award all of the Work to a single Bidder or may award portions of the Work to more than one Bidder.

SECTION 7.0 GENERAL PROVISIONS

7.1 Form of Agreement

- a. At the OWNER'S option, the Agreement may be a Purchase Order issued by the OWNER in acceptance of CONTRACTOR'S bid, or the Agreement may be a Contract signed by an authorized person employed by the successful bidder and by the representative of the City authorized by the Lakeland City Commission. The words "Contract" and "Agreement" are used interchangeably herein.
- b. Any valid exceptions to the OWNER'S Specification stated in the bid will be considered and if acceptable to the OWNER, adjustment will be made to final specification and/or in the Purchase Order or Contract.

7.2 Change Orders

- a. Changes in the Work. The OWNER may, during the progress of the Work, order extras to the contract requirements or make changes in writing in the amount of the Work as specified without invalidating the Contract. No claim for additional compensation will be allowed unless covered by such an order. Change orders shall include a negotiated lump sum amount or agreed upon unit price. All claims for extension of time due to such changes shall be approved at the time of authorization for such changes.
- b. Any plan of action, method of work, or construction procedure suggested orally or in writing to the CONTRACTOR by any OWNER employee, agent which is not set out in Change Orders or other written directives issued in accordance with the Contract Documents, if adopted or followed by the CONTRACTOR in whole or in part, shall be performed at the sole risk and responsibility of the CONTRACTOR.

7.3 Project Schedules

- a. Project Schedules will consist of multiple work assignments given by the OWNER.
- b. Completion of the Work. The CONTRACTOR shall complete the Work within the time specified in the order, or as extended by written order.
- c. Execution of the Work. The CONTRACTOR shall prosecute the Work continuously in such a manner and in such order of precedence as may be directed by the OWNER, working overtime, if necessary, to meet the specified dates.

- d. Time is of the essence to this Contract and the CONTRACTOR agrees, at no additional cost to the OWNER, to take all steps necessary to meet the completion dates stated in the OWNER'S production schedules. In the event the CONTRACTOR falls behind any of the project schedules at any time during the performance of this Contract, the CONTRACTOR shall immediately and/or upon notification from the OWNER, work overtime and/or add workers, and/or take other action as may be necessary to promptly bring the Work back on schedule.

7.4 Subcontractors

The CONTRACTOR shall obtain prior consent of the OWNER before entering into subcontracts for any part of the Work.

7.5 Back-Charges

- a. If at any time the CONTRACTOR requests the OWNER to do any work to assist the CONTRACTOR in any manner, OWNER may invoice the cost of such work, and the CONTRACTOR shall make payment to the OWNER by submitting actual payment to the OWNER, or by indicating a credit on the very next invoice submitted to the OWNER.
- b. Should any work done require correction because of faulty workmanship or materials; or should the materials as supplied or as installed require corrective work the OWNER shall notify the CONTRACTOR and proceed as follows:
 - i. If the OWNER'S time schedule permits, the CONTRACTOR will be allowed to perform the corrective work and bear all costs.
 - ii. If the OWNER'S time schedule does not permit the action described above, or if the CONTRACTOR refuses or neglects to take immediate action, the OWNER shall have the right to perform the corrective work, exercising due care to ensure the lowest possible expense, and the CONTRACTOR shall reimburse the OWNER for the cost of the corrective work.

7.6 Payment

- a. CONTRACTOR shall submit a schedule of values and a CPM for approval by the OWNER. Milestones shall be assigned a value as a percentage of total work. Upon completion of a milestone, CONTRACTOR shall submit an invoice identifying the milestone/or milestones completed. The OWNER shall review the invoice, verify the completion of the milestone, and if accepted, pay the invoiced amount less a 10% retainage. Payments on account, on the contract sum, and for any added work which may have been authorized shall be made at the times and in the manner set forth in the contract, but only after the OWNER has approved the amount of each payment as it shall fall due.
- b. The CONTRACTOR shall, before applying for payment, submit to the OWNER, in such form as the OWNER may direct, a schedule of values of the various parts of the Work according to the Unit Prices of the Contract, divided so as to facilitate the evaluation of work, for which payment is to be made, by the OWNER.
- c. When a payment falls due, the CONTRACTOR shall submit an application for payment based upon the schedule mentioned in the paragraph immediately above and in such for as the OWNER may direct.
- d. If the CONTRACTOR has made applications as required above, the OWNER shall review the amount requested and, if satisfactory, approve the CONTRACTOR'S invoice for payment.
- e. If payments are made on account of materials delivered and stored at the site, but not incorporated in the work, they shall be conditional upon submission by the CONTRACTOR of bills

of sale, or such other procedure as will establish the OWNER'S title to such material or otherwise adequately protect the OWNER'S interest. The CONTRACTOR shall be fully responsible for such materials until they are incorporated into the work.

- f. No payment or partial payment made by the OWNER to the CONTRACTOR shall be an acceptance of any work or material not in accordance with the contract documents.
- g. Terms of payment. If the CONTRACTOR'S payment terms are not accepted by the OWNER, payment shall be made in a lump sum (minus ten percent retainage) upon satisfactory completion of the work and receipt of invoice from the CONTRACTOR subject only to the following specified provisions.
 - i. Final acceptance will not be considered until all requirements of this specification have been met by the CONTRACTOR and approved by the OWNER.
 - ii. The final payment, equal to the retainage permitted under Florida Statute §255.078 shall be withheld until acceptance of the total job.
 - iii. When, in the opinion of the CONTRACTOR, the work covered by this specification has been completed the CONTRACTOR shall submit a "Request for Final Payment", along with any and all documentation necessary to satisfy the OWNER that all bills for labor, material, lands, licenses, fees, or any other expenses, have been satisfied, and a copy of the Final Report to the OWNER. The OWNER shall review the request, submitted documentation, and Final Report, and, if the work is acceptable to the OWNER and the documentation is sufficient to satisfy the OWNER of full payments by the CONTRACTOR, the OWNER shall make payment of the retained funds to the CONTRACTOR within thirty (30) days of receipt of all the above listed documents. Upon receipt of said retained funds, the CONTRACTOR shall agree to release the OWNER from any and all claims against the OWNER from future claims, actions, and liens.

7.7 Invoices

The CONTRACTOR shall submit an invoice to the OWNER each time a payment falls due. Separate invoices shall be submitted for each work order assignment.

- a. All invoices shall be sent to Lakeland Electric finance at:
Lakeland Electric Finance
Accounts Payable, Mail Code: CH-AP
228 S Massachusetts Avenue
Lakeland, FL 338010

With a Copy of the invoice sent to:

Lakeland Electric
McIntosh Power Plant-Production
3030 Lake Parker Drive
Lakeland, FL 33805
ATTN: Matt Brown

- b. OWNER may withhold payment if the CONTRACTOR is in violation of any terms and conditions of the Contract Documents

7.8 Substitutions

- a. No substitutions shall be made for materials or equipment or components thereof which are specified by generic type, except upon written approval by the OWNER.
- b. The CONTRACTOR shall submit all requests for approval of substitutions in writing, stating the reason for the request and attaching technical evidence of the equivalency of the proposed substitute.

7.9 Performance Guarantee and Equipment Warranty

The CONTRACTOR will provide a guarantee and warranty as follows:

- a. Performance: The CONTRACTOR shall guarantee that the supplied equipment shall perform as specified. Replacement or revisions required to meet specified performance shall be at the CONTRACTOR'S expense.
- b. Equipment:
 - i. All equipment and component parts shall have a minimum guarantee against fault in design, defective or improper materials, poor workmanship, and failure from normal usage for one (1) year after being placed in the specified service, and/or eighteen (18) months after date of shipment. Repair or replacement parts and labor required during this period shall be furnished at the CONTRACTOR'S expense, F.O.B. installed at OWNER'S jobsite.
 - ii. The CONTRACTOR shall ensure the availability of equipment in the event of warranty failures. Immediate response to failures is essential. If equipment fails during the warranty period, the CONTRACTOR shall provide replacement equipment at no cost to the OWNER, while the failed equipment is being repaired.

The CONTRACTOR shall ensure the availability of equipment in the event of warranty failures. Immediate response to failures is essential. If equipment fails during the warranty period, the CONTRACTOR shall provide replacement equipment at no cost to the OWNER, while the failed equipment is being repaired.

7.10 CONTRACTOR'S Obligations

- a. The CONTRACTOR shall, in a good and workmanlike manner, perform all work and furnish all labor and services, except as herein otherwise expressly set forth, necessary to perform and complete all the Work required by this Contract, in accordance with the provisions of the Contract Documents and any and all supplemental plans and drawings.
- b. The CONTRACTOR shall furnish all materials required to complete the Work except those specifically identified herein as being supplied by the OWNER. Where specified, all materials must conform to this Specification. Materials not specified are subject to the OWNER'S approval.
- c. The CONTRACTOR shall furnish all lights, tools, and equipment (including cherry pickers or cranes if required by the CONTRACTOR'S construction plan). All equipment brought on the Jobsite shall be certified to OSHA or local regulations and the operators shall be qualified to operate the equipment.
- d. Unless otherwise specified, all materials and equipment, supplied by the CONTRACTOR and permanently incorporated in the Work, shall be new and unused. Both material and equipment shall be of good quality. The CONTRACTOR shall, if required, furnish satisfactory evidence as to the source of supply and quality of the material and equipment.

- e. No materials, equipment or supplies to be incorporated in the Work shall be purchased by the CONTRACTOR or by any subcontractor subject to any chattel mortgage or under a conditional sale contract or other agreement by which an interest is retained by the CONTRACTOR. The CONTRACTOR warrants good title to all materials supplied by the CONTRACTOR in the Work, free from all liens, claims and encumbrances.

7.11 CONTRACTOR'S Cooperation

- a. The CONTRACTOR, its agents, and employees shall use diligence in cooperating with the OWNER, its agents, its other contractors, employees, suppliers and their agents, and employees in coordinating the work hereunder with other work at the Jobsite, all regardless of whether the OWNER'S agent, employees, or OWNER'S other contractors and suppliers, and their agents and employees are, or are not, affiliated with any labor union.
- b. The CONTRACTOR, its subcontractors, agents and employees shall in no way delay or alter the Work at the Jobsite on account of the other work being furnished or performed, or not furnished or performed, by union labor, subject to the other provisions of the Contract.
- c. The CONTRACTOR shall provide proper attention to the Work, shall keep an authorized representative on the Jobsite who shall be authorized to act upon notices, directions, and instructions. The CONTRACTOR will, before proceeding with the Work, provide the OWNER in writing, the name and title of the authorized representative and/or field superintendent and such representative shall be acceptable to the OWNER.
- d. The CONTRACTOR shall immediately remove from the job any person considered by the OWNER to be dishonest, incompetent, disposed to be disorderly, or for any reason unsatisfactory or undesirable to the OWNER and such person shall not again be employed on the premises without the consent of the OWNER.

7.12 Assignment

Neither party shall assign any of its rights, obligations, or duties under the terms and conditions of this Specification or any ensuing Agreement without the express written consent of the other party.

7.13 Codes and Regulations

- a. All materials and equipment shall be in accordance with any and all applicable Federal, State, and Local codes, laws, and ordinances in effect at the jobsite. All of the above referenced codes, laws, and ordinances shall take precedence over these specifications in case of any conflict. All such conflicts shall be referred to the OWNER for adjudication.
- b. The following industry, association, and government codes and standards shall be followed as applicable to the design, fabrication, assembly, installation, and testing of all materials and equipment furnished under this specification:
 - AISC – American Institute of Steel Construction
 - AISI – American Iron and Steel Institute
 - ANSI – American National Standards Institute
 - ASME – American Society of Mechanical Engineers
 - ASTM – American Society of Testing and Materials
 - AWS – American Welding Society
 - F.M. – Factory Mutual
 - IEEE – Institute of Electrical and Electronics Engineers
 - NACE – National Association of Corrosion Engineers

- NEMA – National Electrical Manufacturers Association
- NERC – North American Electric Reliability Corporation
- OSHA – Occupational Safety and Health Administration
- SBCC – Southern Building Code Congress
- SSPC – Structural Steel Painting Council
- U.L. – Underwriters Laboratories

- c. The issue or revisions of these documents in effect on the date of the Purchase Order shall apply.
- d. In the event of a conflict between any portion of this Specification and the referenced specifications, data sheets, Manufacturer's product information, and drawings, such conflicts shall immediately be brought to the OWNER's attention and the OWNER shall determine which document prevails.

7.14 OWNER'S Representative

The OWNER will assign one or more individuals as Field Representative(s) for this Project. Throughout the duration of this Contract, all questions concerning this Project shall be directed to a Field Representative. It will be the Field Representative's responsibility to coordinate with necessary OWNER personnel as required, including arranging for the tagging of equipment when removed from service for the CONTRACTOR.

7.15 Inspection

Authorized agents of the OWNER shall be allowed free and ready access to the CONTRACTOR'S work area, shops and the shops of its suppliers, at all reasonable times, for the purpose of inspecting the equipment or material, or any of its parts and to obtain information as to the progress of the work. Failure on the part of the OWNER to discover or reject materials or work not in accordance with the specified requirements shall not be deemed an acceptance thereof or a waiver of defects therein.

7.16 Fire Protection

The CONTRACTOR, throughout the entire performance of this contract, shall provide any special fire protection not furnished by the OWNER, in accordance with applicable National Fire Protection Association (NFPA) Codes, and OSHA, for all work involving cutting, burning, or operations that use an open flame or produce sparks as governed by this contract. The CONTRACTOR shall obtain a "Hot Work Permit" from the OWNER prior to beginning any daily work involving cutting, burning, or welding on the job site. If a determination is made by the OWNER that a fire watch is required in the area of work, the CONTRACTOR shall furnish a person or personnel for this duty.

7.17 Site Clean Up

- a. The CONTRACTOR shall keep the premises free at all times from accumulation of waste materials and rubbish caused by construction operations and employees.
- b. The CONTRACTOR shall furnish all refuse containers required for the Work and will arrange for the periodic removal and emptying of the same.
- c. The CONTRACTOR shall perform final cleanup prior to OWNER'S acceptance of the Work. The final cleanup shall include:
 - i. Removal of dirt and unsightly substances from all visible surfaces and areas.
 - ii. Removal of CONTRACTOR'S temporary structures, tools, equipment, supplies and surplus materials.

- iii. Repair of roads, walks, fences and other items damaged or deteriorated because of CONTRACTOR'S operations.
- iv. Grading, raking, smoothing, replacing vegetation and other operations necessary to restore to original or better condition all areas affected by CONTRACTOR'S operations.
- v. The CONTRACTOR shall be responsible for disposing of all waste materials and rubbish generated (paint, waste, etc) off site in accordance with all applicable laws, rules, regulations and ordinances.

7.18 Plant Location and Access

- a. The Larsen plant is located at 2002 U.S. Hwy. 92 East in Lakeland, Florida.
- b. The McIntosh plant is located at 3030 East Lake Parker Drive in Lakeland, Florida.
- c. The Winston Station is located at 1200 Airport Road in Lakeland, Florida.
- d. The sites are approximately 140 feet above sea level with an ambient temperature range of +20°F to 120°F, and 50 to 100 percent relative humidity.

7.19 Entrance Gate and Parking

- a. The CONTRACTOR'S vehicles shall enter the plant site only through the specified entrance gate. All vehicles leaving the OWNER'S property are subject to inspections.
- b. The CONTRACTOR and its subcontractors shall each be limited to bringing only two (2) vehicles inside of the fenced plant perimeter. All vehicles brought on site must be clearly marked with the CONTRACTOR'S business logo or other identifying mark so that the OWNER may positively determine who an unattended vehicle belongs to.
- c. The OWNER reserves the right to further limit the number of vehicles brought on site by a CONTRACTOR if necessary.
- d. No personal vehicles shall be allowed within the fenced perimeter of the site. The CONTRACTOR'S personnel shall park only in designated areas and shall enter the site only through the designated gate. Any vehicles brought on site within the fenced perimeter of the site shall be "parked at your own risk." The OWNER shall have no responsibility or liability for any damage whatsoever caused to vehicles parked within the fenced perimeter of the site.
- e. The security forces employed by the OWNER have total site responsibility. All personnel entering or leaving the site must be logged in and out by security. Security personnel enforce safety regulations on site and assist in removal of undesirable personnel. Failure to obey instructions of security personnel is considered grounds for removal from Jobsite.

7.20 Operations Interference

For any work performed in a plant, the CONTRACTOR shall in no way interfere with normal operations. All work must be planned and coordinated through the OWNER Representative.

7.21 Royalties and Patents

By accepting any contract or work order resulting from the Specification, the CONTRACTOR agrees to indemnify the OWNER and to hold the OWNER harmless in respect to any and all claims that material sold hereunder infringes any U.S. or foreign letters patent, copyright or trademark and, provided the OWNER gives CONTRACTOR prompt notice in writing of any suit or action at law or in equity brought against the OWNER or any claim for infringement and gives CONTRACTOR necessary information, assistance, and authority to do so, the CONTRACTOR agrees to defend at the CONTRACTOR'S expense any and all such suits, and to satisfy any judgment entered therein. If, as the result of such suit, the equipment or any part thereof is held to constitute infringement the CONTRACTOR at its option and

expense shall either procure for the OWNER the right to continue using the equipment, or replace same with non-infringing equipment, or modify the equipment so that it becomes non-infringing.

7.22 Damages to Asbestos Designated Equipment

Prior to the initiation of the contracted work, the CONTRACTOR shall meet with the Safety Officer to discuss necessary guidelines for working in the vicinity of asbestos. In addition, the CONTRACTOR shall be responsible for the replacement or repair of damages to any designated asbestos insulation caused by any of the CONTRACTOR'S employees. The CONTRACTOR must sign a statement, provided by OWNER, verifying this requirement.

7.23 Licenses and Insurance

The CONTRACTOR will obtain and maintain, at its own expense, all licenses and insurance to comply with all City, County, State and Federal requirements.

7.24 Default

Each of the following shall constitute a default under this Agreement:

- a. CONTRACTOR is adjudged to be bankrupt;
- b. CONTRACTOR makes a general assignment for the benefit of its creditors;
- c. CONTRACTOR fails to comply with any of the terms, conditions or provisions of this Agreement;
- d. or CONTRACTOR'S experiencing a labor dispute which threatens to have a substantial, adverse impact upon performance of this Agreement.

If, during the term of this Agreement, CONTRACTOR shall be in default of this Agreement, OWNER may suspend its performance hereunder until such delinquency or default has been corrected; provided, however that no suspension shall be effective unless and until OWNER gives written notice of default to CONTRACTOR with at least (10) days to cure such default. If CONTRACTOR fails to correct such delinquency or default, OWNER may terminate this Agreement and pursue such remedies as may be available at law or in equity. CONTRACTOR shall be paid compensation for services satisfactorily performed and completed as of the date of termination. OWNER shall not be liable for partially completed Work. In addition to the remedies available hereunder, the OWNER shall have the right of offset from sums or payments otherwise due the CONTRACTOR, any sums or amounts which the CONTRACTOR may owe to the OWNER pursuant to the provisions of this Agreement and seek such remedy as may be available, including, but not limited to satisfaction of the performance bond. It is not the intention of this paragraph to limit or prevent delay damages or other damages that may occur.

7.25 Termination for Convenience

Notwithstanding any other provision of this Agreement, OWNER may, upon prior written notice to CONTRACTOR, terminate this Agreement with or without cause. In the event of such termination, OWNER shall be liable only for the payment of all unpaid charges, determined in accordance with the provisions of this Agreement, for work, properly performed prior to the effective date of termination.

7.26 Delay

If the CONTRACTOR fails to complete the work, or any part thereof, in the time agreed upon in the multiple project schedules set forth by the OWNER, or within such extra time as may have been agreed to, the CONTRACTOR shall reimburse the OWNER for any additional expense and damage caused by such delay. In the event that the work is not completed by the scheduled date, the OWNER shall be

entitled to withhold final payment plus any unpaid adjustments until such time as the total amount of delay damages is determined and amount caused by such damages shall be withheld from the final payments and any unpaid adjustments then due. The withholding of said amounts from the final payment and any unpaid adjustments shall not impair the OWNER'S right to seek additional remedy or compensation for damages.

7.27 Force Majeure

Neither party shall be liable to the other party for failure to perform or for the delay in performance of this Contract when said failure or delay is due to any cause beyond a party's reasonable control, including, but not limited to, fire, flood, strike or other labor difficulty, acts of any governmental authority, riot, terrorism, embargo, unavailability of railcars, wrecks or delay in transportation, provided that, as a condition to the claim of force majeure, the party experiencing the difficulty shall give the other prompt written notice, with full details following the occurrence of the cause relied upon. Dates by which performance obligations are scheduled to be met will be extended for a period of time equal to the time lost due to any delay so caused. Inclement and severe weather which is typical within central Florida through the period the Work is anticipated shall not entitle a party to claim relief by force majeure or for delay damages.

7.28 Claims and Contract Negotiation

- a. All claims of CONTRACTOR, all questions concerning interpretation or clarification of the Contract or the acceptable fulfillment of the Contract on the part of CONTRACTOR, and all questions as to compensation and to extension of time shall be submitted, in writing, to OWNER for determination.
- b. A claim by CONTRACTOR must be made within 15 calendar days of CONTRACTOR's learning of the cause for the claim. The claim must be submitted to OWNER with as much supporting detail as can be reasonably developed at the time the claim is made. OWNER may grant additional time to develop additional detail to the extent OWNER requires. OWNER will determine the outcome of CONTRACTOR's claim. At all times CONTRACTOR shall proceed with the Work in accordance with the determinations, instructions, and clarifications of OWNER while OWNER is determining the outcome of CONTRACTOR's claim.
- c. If any requirement of the Contract is unclear to CONTRACTOR, CONTRACTOR shall be solely responsible for requesting instructions or interpretations and shall be solely liable for any cost and expenses arising from its failure to do so.
- d. Nothing set forth above shall impair OWNER's rights and remedies to enforce CONTRACTOR's obligations under the Contract.

7.29 Notice

Any notices required to be given by the terms of the Contract shall be delivered by hand or mailed, postage prepaid, to the address below. Either party may change the name of the person receiving notices and the address at which notices are received by so advising the other party in writing.

For City:

City of Lakeland/Department of Electric Utilities
Attention: Contracts

501 E. Lemon Street
Lakeland, FL 33801 5050
(863) 834 6588

Mail Code: LE-CONTRACTS

e-mail: contracts@lakelandelectric.com

With a copy to:

CITY OF LAKE LAND
DEPARTMENT OF ELECTRIC UTILITIES
ATTN: WORK FORCE MANAGEMENT MANAGER
3030 E. LAKE PARKER DR.
LAKE LAND, FL 33805

For Consultant:

Within ten (10) days of the notification that Bidder was successful, Bidder shall submit the name, address, telephone number and email address of the person or persons authorized to accept notices required under the Contract.

7.30 Jurisdiction, Venue and Governing Law

Jurisdiction and Venue shall be in the Courts of Polk County, Florida or the United States District Court in and for the Middle District of Florida, Tampa Division, in connection with any action or proceeding arising out of or relating to this bid, proposal, contract, documents or instrument delivered pursuant to, in connection with, or simultaneously with this bid/proposal or breach of any contract entered into with the City. This Agreement shall be governed by the laws of the State of Florida.

7.31 Public Records

IF THE CONTRACTOR HAS QUESTIONS REGARDING THE APPLICATION OF CHAPTER 119, FLORIDA STATUTES, TO THE CONTRACTOR'S DUTY TO PROVIDE PUBLIC RECORDS RELATING TO THIS CONTRACT, CONTACT THE CUSTODIAN OF PUBLIC RECORDS: KEVIN COOK - DIRECTOR OF COMMUNICATIONS AT: PHONE: 863-834-6264, E-MAIL: KEVIN.COOK@LAKELANDGOV.NET, ADDRESS: ATTN: COMMUNICATIONS DEPARTMENT, 228 S. MASSACHUSETTS AVE., LAKE LAND, FLORIDA 33801.

In accordance with Florida Statute §119.0701, the Contractor shall keep and maintain public records required by the City in performance of services pursuant to the contract. Upon request from the City's custodian of public records, Contractor shall provide the City with a copy of the requested records or allow the records to be inspected or copied within a reasonable time at a cost that does not exceed the cost provided pursuant to Florida Statute Chapter 119 or as otherwise provided by law. Contractor shall ensure that public records that are exempt or confidential and exempt from public records disclosure requirements are not disclosed except as authorized by law for the duration of the contract term and following completion of the contract if the Contractor does not transfer the records to the City. Contractor shall, upon completion of the contract, transfer, at no cost, to the City all public records in possession of the Contractor or keep

and maintain public records required by the City to perform services pursuant to the contract. If the Contractor transfers all public records to the City upon completion of the contract, the Contractor shall destroy any duplicate public records that are exempt or confidential and exempt from public records disclosure requirements. If the Contractor keeps and maintains public records upon completion of the contract, the Contractor shall meet all applicable requirements for retaining public records. All records stored electronically must be provided to the City, upon request from the City's custodian of public records, in a format that is compatible with the information technology systems of the City.

SECTION 8.0 SPECIAL REQUIREMENTS

8.0 Right to Offset

In addition to other remedies available under this Contract, the OWNER shall have the right to deduct, offset against, or withhold from sums or payments otherwise due the CONTRACTOR any sums or amounts which the CONTRACTOR may owe to the OWNER pursuant to provisions of this contract, as a result of any breach or termination of this contract.

ATTACHMENT 1

Insurance Requirements

Will be determined by RISK MANAGEMENT and added by PURCHASING

ATTACHMENT 2

Safety Requirements

Will be determined by RISK MANAGEMENT and added by PURCHASING



Plant Welder II

Bargaining Unit: Utility Workers Union of America

GENERAL DESCRIPTION OF CLASS:

This is journey level work in performing advanced welding procedures. Work involves the responsibility for performing skilled journey level tasks in high pressure code welds, alloy welds, carbon steel welds and similar welds of an advanced nature. Work also entails mechanical maintenance of high pressure steam power plant equipment. Assignments also involve the limited supervision of subordinates. Duties are performed under general supervision and are subject to inspection by a superior for work quality upon completion.

EXAMPLES OF DUTIES:

- Performs high pressure code welds, alloy welds, carbon steel welds, brazing cast iron welds and spot welding on machinery and equipment.
- Performs acetylene gas welding, cutting and carbon arc air cutting.
- Reads blueprints, does layout work and pipe fitting.
- Assists other crafts in various types of mechanical work on compressors, fans, valves, boilers, turbines and other associated power plant equipment.

ADDITIONAL RESPONSIBILITIES:

- Performs related work as required.

QUALIFICATIONS:

- High school diploma from an accredited school or its equivalent.
- Two (2) years of experience in welding work at the level of a Plant Welder I.
- Must be certified as a code welder under the A.S.M.E. Code requirements in the 6G position.
- An equivalent combination of education, training and experience which provide the necessary knowledge, skills and abilities and other competencies necessary for success in the target position.

Required Documents: GED, High School Diploma, College Diploma or Unofficial Transcripts

SPECIAL REQUIREMENTS:

- Must have completed a course in welding fabrication and layout that is approved by the City.
- Must possess and maintain a valid state of Florida driver's license.
- Must be willing and able to maintain a valid telephone number.
- May be required to pass and maintain qualification for:
 - Respiratory Protection Physical
 - Pulmonary Function
 - Qualitative and Quantitative Fit Test(s)
- May be required to work overtime, or alternate hours, as necessary for the efficient operation of the department.
- Position may be designated as Mission Critical by Department Director.

KNOWLEDGE, SKILLS, ABILITIES, COMPETENCIES:

- Considerable knowledge of the practices, materials, methods and tools used in advanced welding.
- Considerable knowledge of the occupational hazards and safety precautions of the welding trade.
- Ability to supervise and direct the work of others as necessary.
- Ability to work independently and to understand and carry out complex oral and written instructions.

WORKING ENVIRONMENT/CONDITIONS:

- Requires physical work that involves walking or standing some of the time, exerting up to 50 pounds of force on a recurring basis, working in confined spaces and routine keyboard operations.
- Requires balancing, climbing, crawling, sitting, stooping, stretching, kneeling, reaching, pushing, pulling, crouching and bending over repetitively.
- Job risks exposure to hot/cold temperatures, adverse weather conditions, intense sunlight glare, and wet, humid conditions may be encountered during the performance of job duties.
- Job risks include chemical, biological, electrical and mechanical hazards, moving machinery, extreme heights, toxic, noxious fumes, vibration, dusts, pollen, bright/dim lights, and extreme noise levels.
- Requires normal visual acuity, field of vision, hearing, speaking, color perception, sense of smell, depth perception, texture perception and use of a respirator or face mask.

THE CITY OF LAKE LAND IS AN EQUAL OPPORTUNITY/EQUAL ACCESS EMPLOYER AND A DRUG FREE WORKPLACE

ATTACHMENT 4

LAKELAND ELECTRIC OUTAGE MAINTENANCE SCHEDULE SPRING 2018 THROUGH FALL 2023

Revised 4/24/2018

Outage for units not listed will be scheduled on an as needed basis

"OUT" = 1st day unit unavailable for load
"IN" = 1st day unit on line.

SPRING:			"FY 2018"		DATE	DATE	DURATION	
UNIT NAME			"OUT"	"IN"			OF OUTAGE	
McINTOSH #3	Turbine:	No. 2 Turbine CV	3/17/2018	4/30/2018	44	DAYS		
	Boiler:	No. 3 Heater, Expansion Joints, Scrubber Bypass Duct Removal, R.H. Coil Replacement, HEP (Phase II), Boiler Supply and HEP Hanger Install, Electro-Matic Safety Removed and Capped, #33 and #34 Pulverizer Classifier Modification;						
	Auxiliary:	Electrical switchgear upgrade						
SPRING:			"FY 2019"		DATE	DATE	DURATION	
UNIT NAME			"OUT"	"IN"			OF OUTAGE	
McINTOSH #5	Turbine:	ST L-0 and CT row one blade borescope	10/20/2018	10/27/2018	7	DAYS		
	Boiler:							
	Auxiliary:							
SPRING:			"FY 2019"		DATE	DATE	DURATION	
UNIT NAME			"OUT"	"IN"			OF OUTAGE	
McINTOSH #3	Turbine:	TBD	2/9/2019	3/25/2019	44	DAYS		
	Boiler:	Scrubber Ductwork						
	Auxiliary:	Routine Maintenance, Electrical switchgear upgrades						
SPRING:			"FY 2019"		DATE	DATE	DURATION	
UNIT NAME			"OUT"	"IN"			OF OUTAGE	
McINTOSH #5	LTMA	CT: Combustor Inspection	4/20/2019	5/13/2019	23	DAYS		
	HRSG:	HRSG Inspection (Level 1)						
	ST:							
	Contract:	BOP Valve Inspection, HRH Bypass Valve						
	City:	Unit Maintenance, HRSG Tube Samples						
FALL:			"FY 2019 - 2020"		DATE	DATE	DURATION	
UNIT NAME			"OUT"	"IN"			OF OUTAGE	
LARSEN #8	LTMA	CT: Rotor swap	8/24/2019	12/28/2019	126	DAYS		
	HRSG:	HRSG Inspection						
	ST:	Condenser work						
	Contract:	BOP Valve Inspection						
	City:	Unit Maintenance, Atomizing air cooler, Control system						
SPRING:			"FY 2020"		DATE	DATE	DURATION	
UNIT NAME			"OUT"	"IN"			OF OUTAGE	
McINTOSH #3	Turbine:		3/7/2020	4/20/2020	44	DAYS		
	Boiler:	Water Wall Panels, Expansion Joints,						
	Auxiliary:	Electrical switchgear upgrade, Inspect circ. water coating						

\\COL-DATA\Info\WFM\MATBR\WFM\Special Projects\Outages\Copy of Copy of 5 Year Outage Forecast 042418 KR.xlsx

Welding Positions

FILLET WELDS

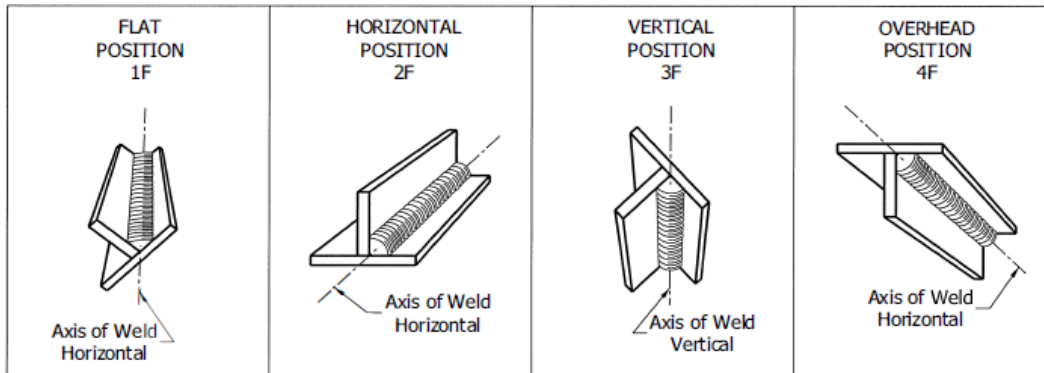

GROOVE WELDS

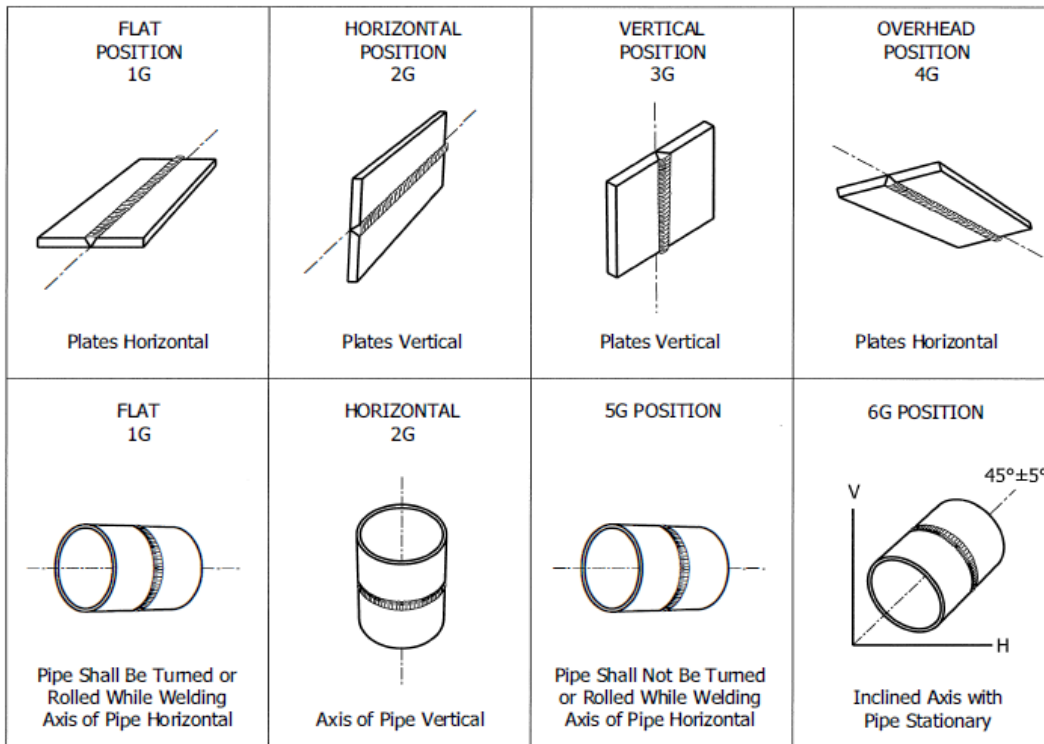

Figure 1

ATTACHMENT 6

PIPE QUALIFICATION TEST PROCEDURE 1023-G

(Revised 09-05-14)

1. Retrieve Applicant Information

- A. Name
- B. Social Security Number (last four digits)
- C. Date

2. Explanation:

- A. Applicant will have (8) hours to complete the test.
- B. This is an open butt test welded uphill in the 6G position.
- C. Coupon material is SA-335-P22, 2-1/2" OD. X .552 MW.
- D. Filler material is ER90S-B3 and E9018-B3
 - 1. Root and hot pass will be GTAW.
 - 2. Inter pass and final will be SMAW using stringer beads.
- E. Preheat temperature will be 300 degrees min.
- F. TIG rig shield gas 12-18 CFH
- G. Purge gas 5-10 CFH (if used)

3. Test Procedure:

- A. Prepare pipe, beveled end to a feather edge.
- B. Clean off mill scale approximately 1" from the beveled end inside and outside of the coupon.
- C. Use 2" angle to align coupons with a gap of 1/8".
- D. Tape ends of coupons and install purge hose and began purging.
- E. Preheat beveled ends of coupons.

- F. Tack weld coupons 180 degrees apart, using (4) 1/2" tacks.
- G. Feather tacks and have instructor visually inspect.
- H. Tack weld the coupon in the 6G position.
- I. Resume purging and install root pass.
- J. Have instructor visually inspect root pass.
- K. Resume purging and install hot pass.
- L. Have instructor visually inspect hot pass.
- M. Remove purge and complete welding out coupon.
- N. Clean up weld and have instructor visually inspect.
- O. Stamp name, date and last four digits of social security number on coupon.
- P. Instructor fill out QW-484 form and have radiographic tested.

4. Notes:

- A. The information contained on these sheets must be followed. Failure to do so will result in termination of the test.
- B. Only enough test materials required to complete the appropriate test will be issued. Practice coupons will not be permitted.
- C. All test materials will be cleaned and free from rust, oil, grease and mill scale.
- D. Reasonable grinding of starts and stops is acceptable. Excessive grinding will not be permitted.
- E. Failure of visual inspections, such as excessive or insufficient reinforcement, lack of fusion etc. shall result in termination of test.
- F. The weld surface shall be free from coarse ripples, grooves, overlaps, and abrupt ridges and valleys. Surfaces shall be free from undercut, porosity, arc strikes and excessive weld splatter. Failure to do so will result in termination of the test.
- G. Soundness of welds will be established by either radiographic (x-ray) examination or destructive methods (bends).

ATTACHMENT 7

PLATE QUALIFICATION TEST PROCEDURE 1017-PG

(Revised 02-06-18)

1. Retrieve Applicant Information

- A. Name
- B. Social Security Number
- C. Date

2. Explanation:

- A. Applicant will have (4) hours to complete the test.
- B. This is a groove plate test with backing plate welded in the 3G and 4G positions, using a SMAW welding process.
 - C. Coupon material is A36, 4" x 8" x 3/8" thick plate
 - D. Backing strip material is A36, 1-1/2" x 9" x 3/16" thick
 - D. Filler material is E7018
 - E. Preheat and interpass 50 degrees min.

3. Test Procedure:

- A. Prepare coupons and beveled end to a feather edge.
- B. Clean off mill scale approximately 1" from the beveled edge on both sides of the coupons.
 - C. Clean off mill scale on backing strip, on side to be welded.
 - D. Align coupons and center backing strip with a gap of 1/8" to 1/4".
 - E. Tack weld coupons on each end using 1/2" tacks.
- F. Install 4" x 8" x 3/8" flat bar stiffeners on each end of coupon and install a 1-1/2" to 2" weld on each side at end of stiffener.
 - G. Feather tacks.
 - H. **Have instructor visually inspect fit up.**
 - I. Tack weld the coupon in the 3G or 4G position.
- J. Install root pass with at least one restart near center of plate.
- K. Clean up by removing slag and wire brushing.
 - L. **Have instructor visually inspect root pass.**
- M. Complete welding out coupon with at least one restart near center of plate on each pass.
 - N. **Clean up weld and have instructor visually inspect.**
 - O. Lay out cut lines to remove two specimens from each coupon.
 - 1. Four 1-1/2" strips taken from the center of coupon perpendicular to the weld.
 - a. Two for a root bend.

- b.** Two for a face bend.
- P.** Cut test specimens in band saw and stamp or mark sides root or face.
- Q.** Remove backing strip and cap by grinding off flush to base metal.
- R.** Polish weld areas and round off edges to a 1/8" radius with flapper pad.
- S.** Bend plates and have instructor inspect for defects.
- T.** Stamp name, date and social security number on coupon.
- U.** Instructor fill out QW-484 form.

4. Notes:

- A.** The information contained on these sheets must be followed. Failure to do so will result in termination of the test.
- B.** Only enough test materials required to complete the appropriate test will be issued. Practice coupons will not be permitted.
- C.** All test materials will be cleaned and free from rust, oil, grease and mill scale.
- D.** Reasonable grinding of starts and stops is acceptable. Excessive grinding will not be permitted
- E.** Excessive or insufficient reinforcement shall result in unsuccessful termination of test.
- F.** The weld surface shall be free from coarse ripples, grooves, overlaps, and abrupt ridges and valleys. Surfaces shall be free from undercut, porosity, arc strikes and excessive weld splatter. Failure to do so will result in termination of the test.
- G.** Soundness of welds will be established by either radiographic (x-ray) examination or destructive methods (bends).